

# HideAway

Your place to zone out or tune in.



# A place to focus

Isolation isn't about being alone but about having a space to get things done.

We have all embraced online meetings and calls so having a place dedicated to communicate with clients, suppliers and co-workers with the comfort that you have great acoustic privacy and are less likely to be disturbed is essential.

## Privacy For Calls

Connect with your colleagues without disturbing the whole office.

## Zone Out to Zone In.

Need to focus, the acoustic properties of HideAway enable you to zone in on your work.



Focus



Power, USB and USB C enabled

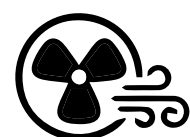

Efficient Ventillation



Private and Individual Working



# Architectural Features:



## Integrated Lighting and Airflow:

As standard all HideAway's are provided with Energy Efficient Occupancy (PIR) activated LED ceiling light and ventilation fan



## A Home from Home:

Wall mounted 'floating' worksurface or table finished in TFL / MFC with integrated power.

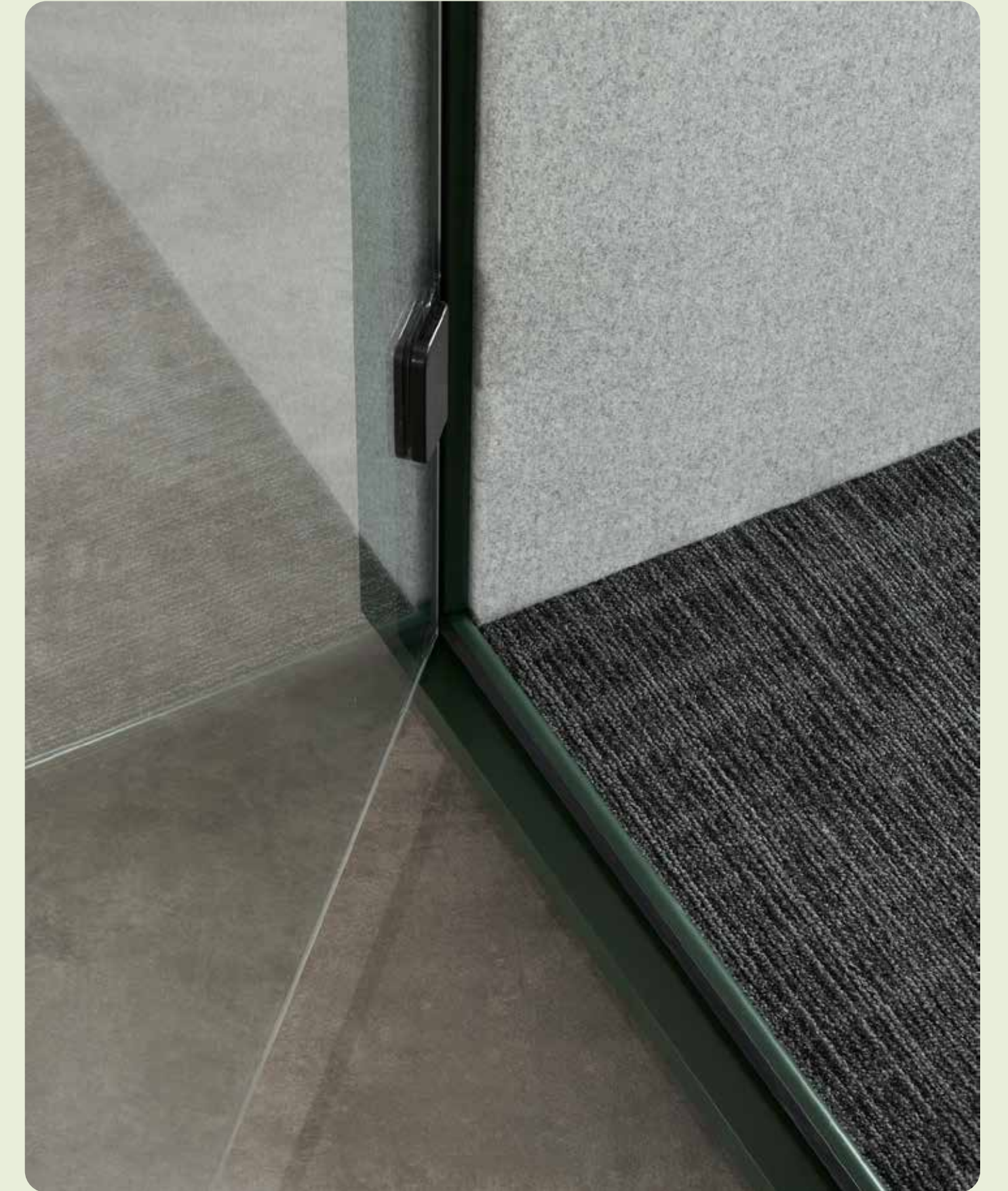

## Functional Exteriors:

The exterior design can be specified to your requirements to create additional collaborative spaces.

# A place for hybrid workers

There are times when you just need to get your head down and focus, this could be producing a report or document or for a longer video call with data being shared.

It can be supplied with an integral bench seat or a stand alone chair can be added. The work-surface provides ample room for a laptop, papers, whilst the connections allow you to hook up to a monitor and camera if you have them installed that create the perfect space for you to participate in a video call.

## Privacy For Calls

Connect with your colleagues without disturbing the whole office.

## Work Without Worry

Need to focus, the acoustic properties of HideAway enable you to zone in on your work.



Focus



Power, USB and USB C enabled

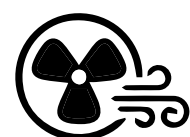

Efficient Ventillation



Private and Individual Working



# Architectural Features:



## **A Home from Home:**

Wall mounted 'floating' worksurface finished in TFL / MFC with integrated power and HDMI connection to the wall mounted monitor.



## **Integrated Lighting and Airflow:**

As standard all HideAway's are provided with Energy Efficient Occupancy (PIR) activated LED ceiling light and ventilation fan



## **Moveable:**

The exterior design can be specified to your requirements from a selection of colors or drywipe to create additional collaborative spaces. The plinth can be removed to allow the fully built pod to be repositioned.

# A place for collaboration

For many now time in the office is about reconnecting with your team, collaborating on a project the HideAway Meeting Pods provide an ideal space for small teams to gather privately, the fantastic acoustic performance allows them to focus on the work they are doing whilst not disturbing others in the office. The ability to add in an optional table or media screen allows ideas to be shared easily and also allows you to connect with remote team members so everyone is on the same page.

## Privacy For Calls

Connect with your colleagues without disturbing the whole office.

## Work Without Worry

Need to focus, the acoustic properties of HideAway enable you to zone in on your work.

## Meet Freely

Meet together for pre-scheduled or ad hoc meetings in-person or online.

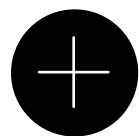

Social



Power, USB and  
USB C enabled



Efficient  
Ventillation



Private and  
Individual Working

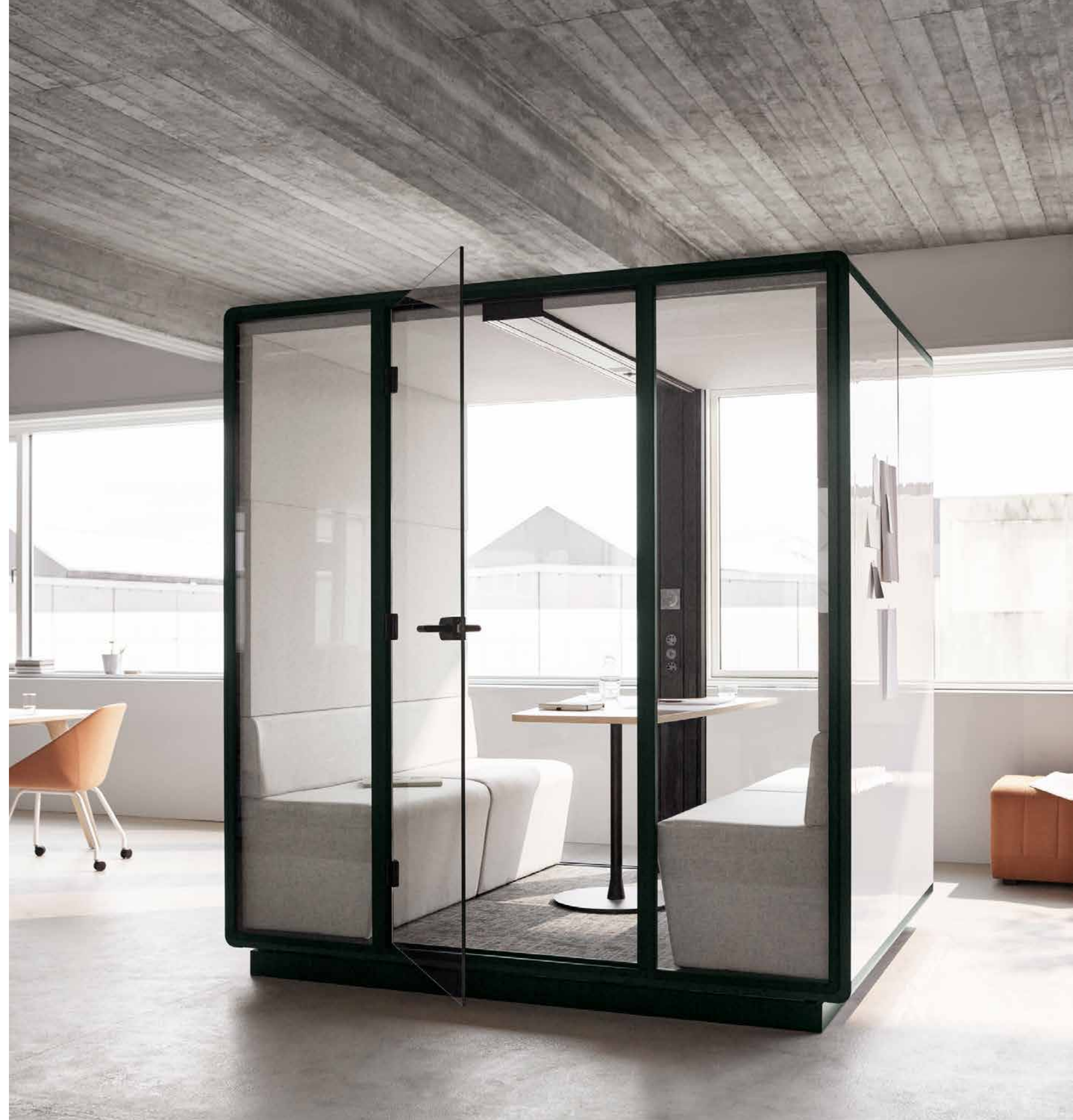

# Architectural Features:



## Thoughtful Design

The architectural detailing and finishes support the integrity of the design. The provision of lighting, airflow, workspaces and power support its functionality. The impressive acoustic performance gives you privacy.

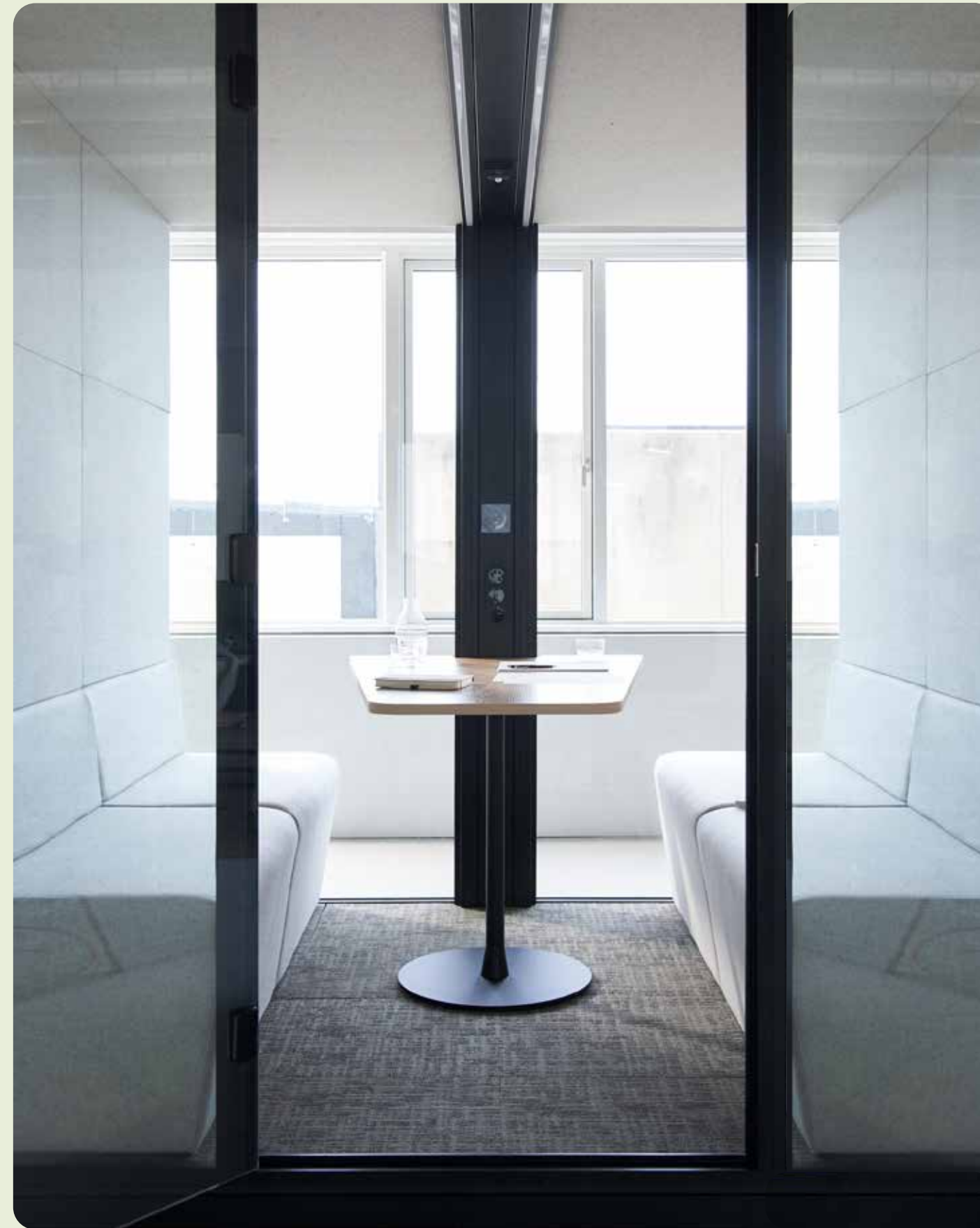

## Well Provisoned

The optional wall mounted meeting table provides a great place to work and its design allows everyone easy access.

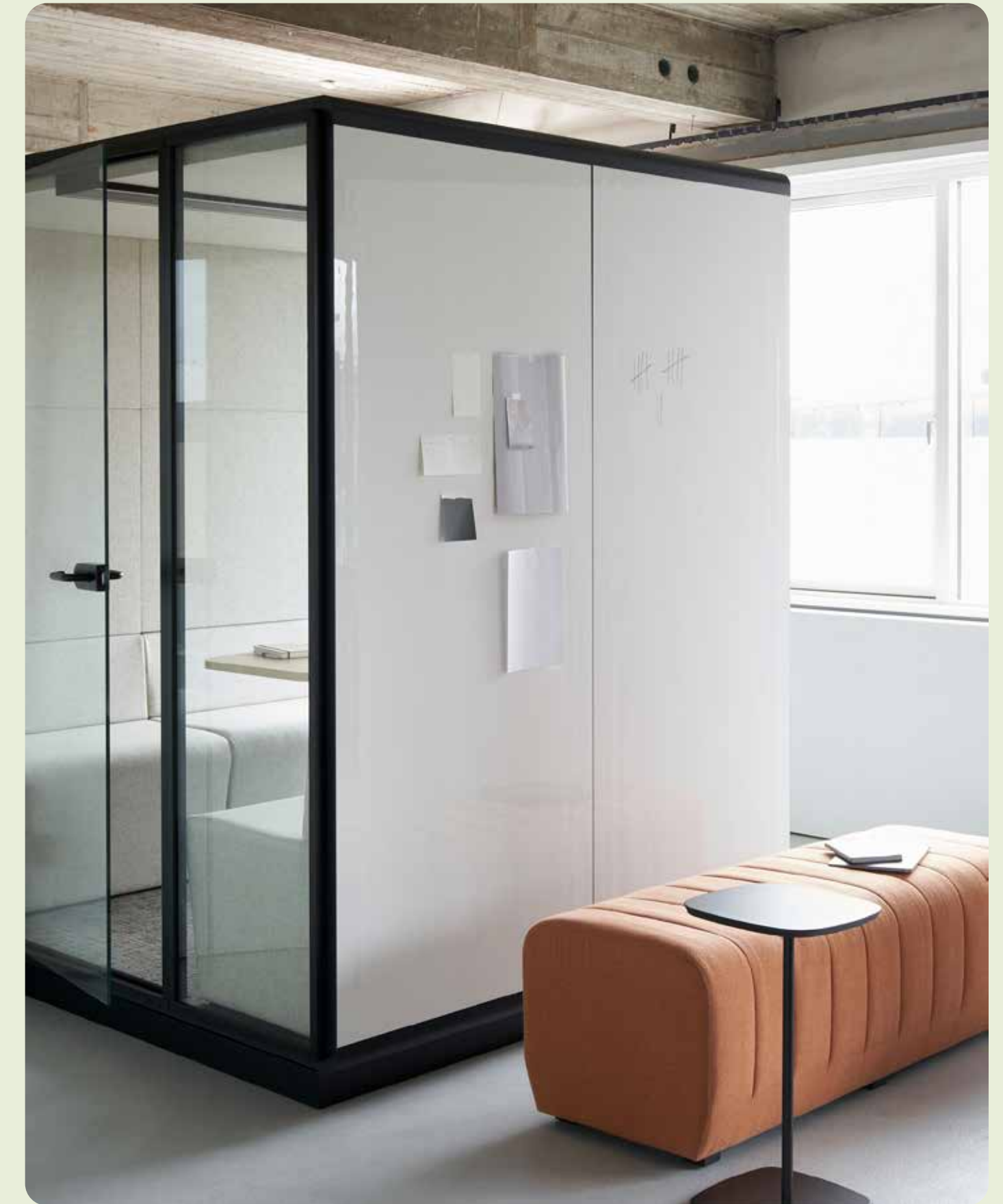

## Functional Exterior

The exterior panels can be specified in a range of colors and TFL finishes to compliment the interior or as dry wipe panels to provide additional collaborative space.

## Zone Out or Tune In.

HideAway is a range of freestanding pods available in 2 - 6 people meeting pods, Telephone Booth and Hybrid Booth designed for privacy and collaboration.

HideAway is an effective solution to empower hybrid workspaces by giving users the acoustic and visual privacy to connect with online and offline colleagues.



**Telephone Booth**  
One person



**Hybrid Work**  
One person

Can be specified without the bench seat to allow a freestanding task chair to be used



**Two Person with Seating**

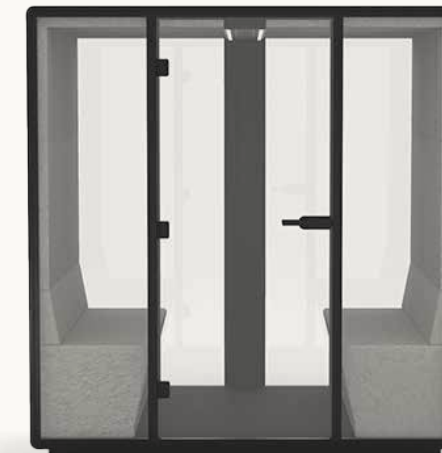

**Four Person**  
Available with and without seating

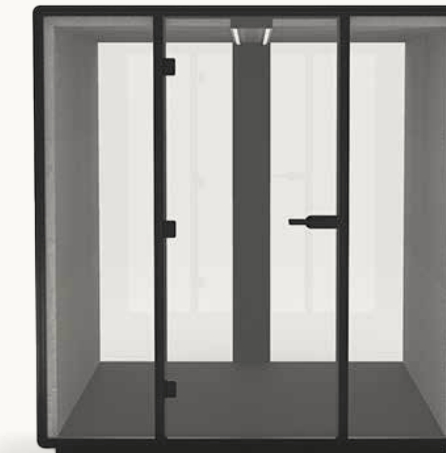

**Six Person**  
Available with and without seating



# In detail

## Telephone Booth One Person

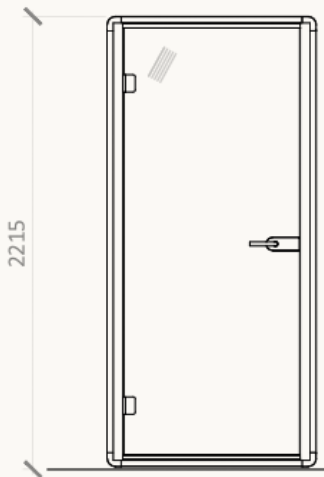
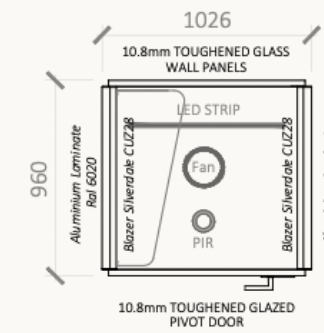

### Dimensions:

OH: 2215mm / 87"  
 OW: 1026mm / 40"  
 OD: 960mm / 38"

### Leveling:

Positioning castors and static position  
 Leveling feet within the base.

**Product Code:**  
 HWY01

### Structural Framework:

Lightweight composite side panels with outer surface covered in Aluminum finished in standard EPC color options

### Glass Panels:

- Glass panels and door, 1/2" laminated clear. Acoustic glass. Front and rear Aluminum Trims finished in Standard EPC color options

### Interior:

- Interior fabric clad acoustic tiles, upholstered in Camira Blazer with Acoustic fibre infill as standard.
- Flooring floor tiles, antistatic, available in two finish colors as standard
- Door hardware finished in Black finish

### Lighting and Airflow:

- Energy Efficient Occupancy (PIR) activated LED ceiling light and ventilation fan
- Optional external occupancy light strip set in the side panels

### Power:

Twin USB A and C 30A power socket

### Workstation:

Wall mounted 'floating' worksurface finished in TFL / MFC. 41.5" AFF (1050mm).

## Hybrid Work Pod One Person

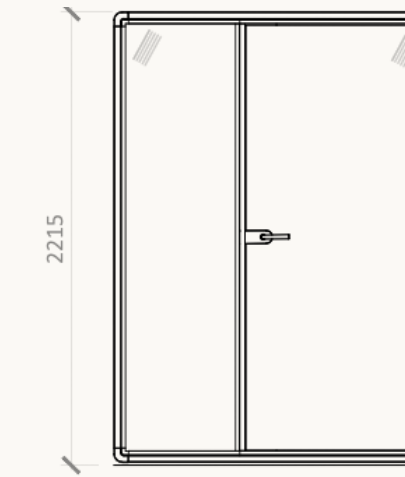
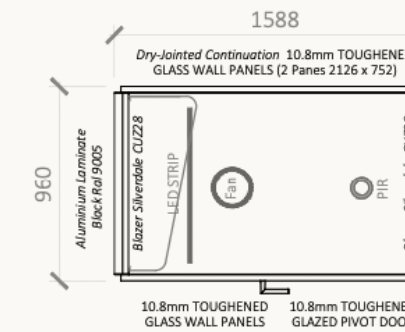

### Dimensions:

OH: 2290mm / 90"  
 OW: 1588mm / 62.5"  
 OD: 960mm / 38"

### Leveling:

Leveling feet concealed behind removable base plinth

Plinth can be removed to enable the fully built pod to be repositioned with appropriate equipment

**Product Code:**  
 HWY05

### Structural Framework:

Lightweight composite side panels with outer surface covered in Aluminum finished in standard EPC color options

### Glass Panels:

- Glass panels and door, 1/2" laminated clear. Acoustic glass. Front and rear Aluminum Trims finished in Standard EPC color options

### Interior:

- Interior fabric clad acoustic tiles, upholstered in Camira Blazer with Acoustic fibre infill as standard
- Flooring floor tiles, antistatic, available in two finish colors as standard
- Door hardware finished in Black finish
- Optional Integrated Bench seating fully upholstered in Camira Blazer

### Lighting and Airflow:

- Energy Efficient Occupancy (PIR) activated LED ceiling light and ventilation fan
- Optional external occupancy light strip set in the side panels

### Power:

2x Power Outlet USB A and C 30A power socket

### Workstation:

- Wall mounted 'floating' worksurface finished in TFL / MFC. 29" AFF (740mm).
- Wall mounted VESA plate to mount Monitor with integrated HDMI connections
- Optional: Can be specified without bench seat to allow a free standing task chair to be used

## Meeting Pod Two person

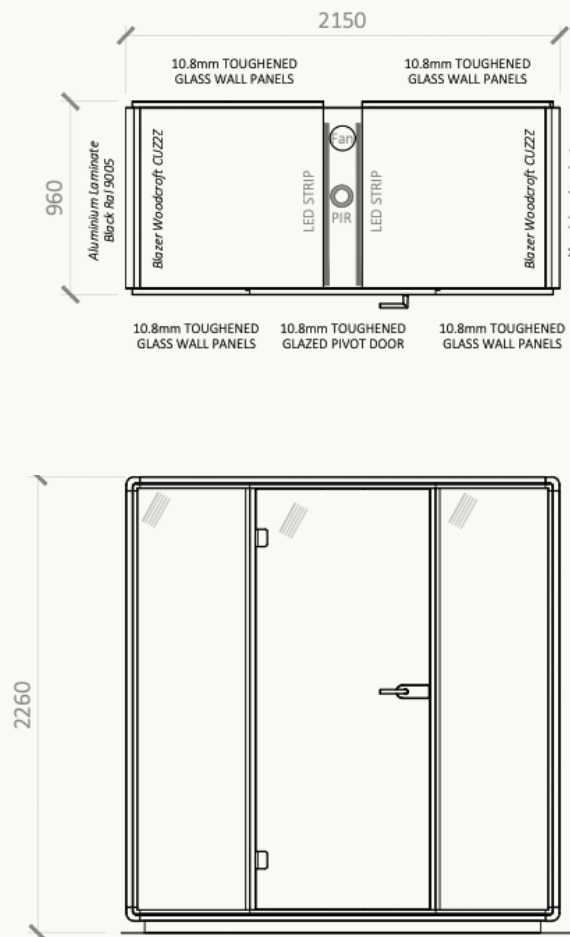

### Dimensions:

OH: 2290mm / 90"  
OW: 2150mm / 85"  
OD: 960mm / 38"

### Leveling:

Leveling feet concealed behind removable base plinth

Plinth can be removed to enable the fully built pod to be repositioned with appropriate equipment

**Product Code:**  
HWY02 / HWY02S

### Structural Framework:

Lightweight composite side panels with outer surface covered in Aluminum finished in standard EPC color options.

### Glass Panels:

- Glass panels and door, 1/2" laminated clear. Acoustic glass. Front and rear Aluminum Trims finished in Standard EPC color options.

### Interior:

- Interior fabric clad acoustic tiles, upholstered in Camira Blazer with Acoustic fibre infill as standard.
- Flooring floor tiles, antistatic, available in two finish colors as standard
- Integrated Bench seating fully upholstered in Camira Blazer
- Door hardware finished in Black finish

### Lighting and Airflow:

- Energy Efficient Occupancy (PIR) activated LED ceiling light and ventilation fan
- Optional external occupancy light strip set in the side panels

### Power:

2x Power Outlet Twin USB A and C 30A power socket

### Workstation:

Optional internal work shelf.

## Meeting Pod Four Person

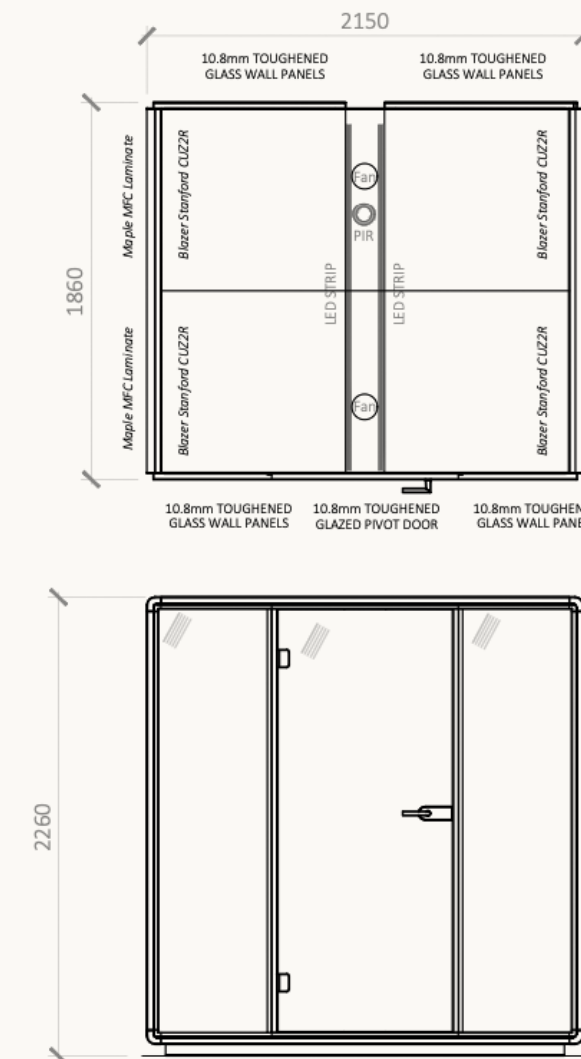

### Dimensions:

OH: 2290mm / 90"  
OW: 2150mm / 85"  
OD: 1860mm / 73"

### Leveling:

Leveling feet concealed behind removable base plinth

Plinth can be removed to enable the fully built pod to be repositioned with appropriate equipment

**Product Code:**  
HWY03 / HWY03S

### Structural Framework:

Lightweight composite side panels with outer surface covered in Aluminum finished in standard EPC color options

### Glass Panels:

- Glass panels and door, 1/2" laminated clear. Acoustic glass. Front and rear Aluminum Trims finished in Standard EPC color options.

### Interior:

- Interior fabric clad acoustic tiles, upholstered in Camira Blazer with Acoustic fibre infill as standard
- Flooring floor tiles, antistatic, available in two finish colors as standard
- Door hardware finished in Black finish
- Optional Integrated Bench seating fully upholstered in Camira Blazer

### Lighting and Airflow:

- Energy Efficient switchable LED ceiling light with two preset illumination levels and ventilation fan
- Optional external occupancy light strip set in the side panels

### Power:

2x Power Outlet Twin Power Outlet USB A and C 30A power socket

### Meeting Table:

- Optional Internal meeting table
- Optional internal VESA mount supports up to a 32" screen with HDMI connections

## Meeting Pod Six Person

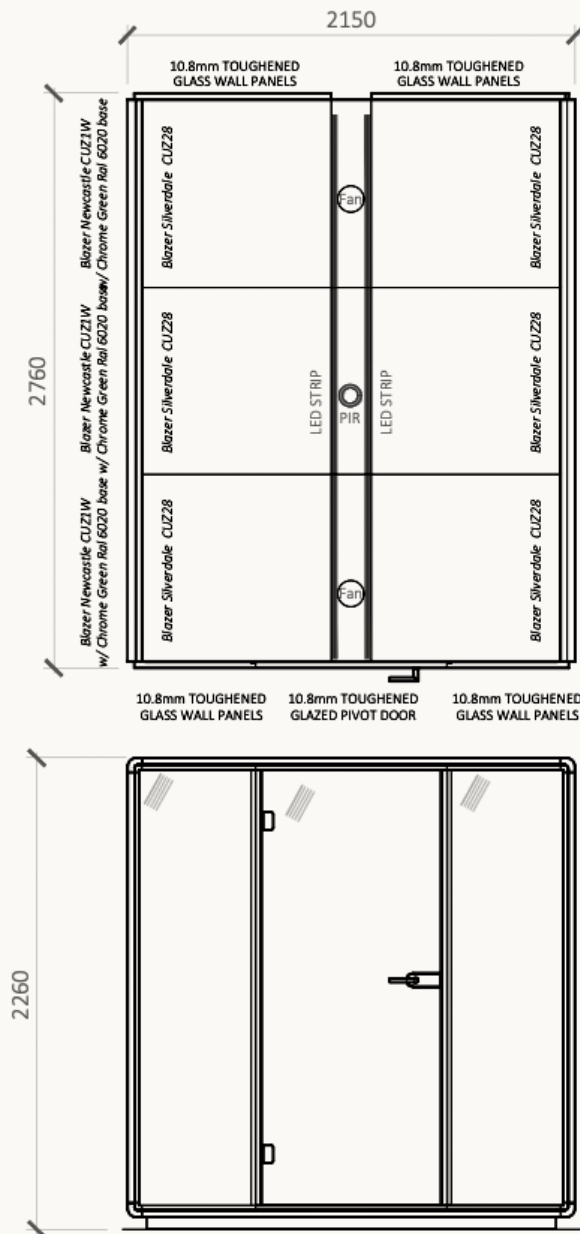

### Dimensions:

OH: 2290mm / 90"  
 OW: 2150mm / 85"  
 OD: 2760mm / 110"

### Leveling:

Leveling feet concealed behind removable base plinth

Plinth can be removed to enable the fully built pod to be repositioned with appropriate equipment

**Product Code:**  
 HWY04 / HWY04S

### Structural Framework:

Lightweight composite side panels with outer surface covered in Aluminum finished in standard EPC color options.

### Glass Panels:

- Glass panels and door, 1/2" laminated clear. Acoustic glass. Front and rear Aluminum Trims finished in Standard EPC color options

### Interior:

- Interior fabric clad acoustic tiles, upholstered in Camira Blazer with Acoustic fibre infill as standard.
- Flooring floor tiles, antistatic, available in two finish colors as standard
- Optional Integrated Bench seating fully upholstered in Camira Blazer
- Door hardware finished in Black finish

### Lighting and Airflow:

- Energy Efficient Occupancy (PIR) activated LED ceiling light and ventilation fan
- Optional external occupancy light strip set in the side panels

### Power:

Twin Power Outlet USB A and C 30A power socket

### Meeting Table:

- Optional Internal meeting table
- Optional internal VESA mount supports up to a 32" screen with HDMI connections

# A world of color



# Paint Finishes



Black

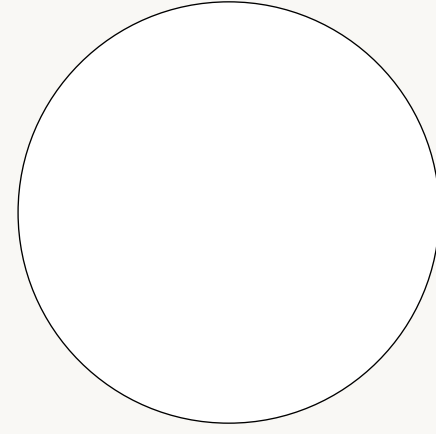

White

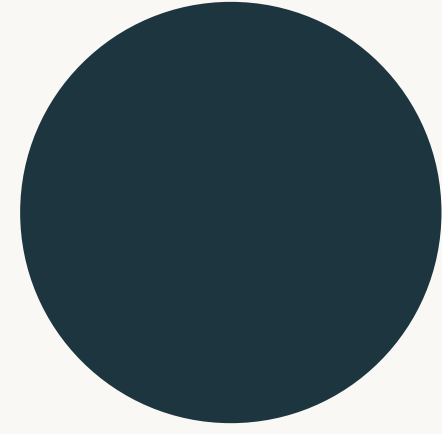

Ocean Blue  
RAL 5020

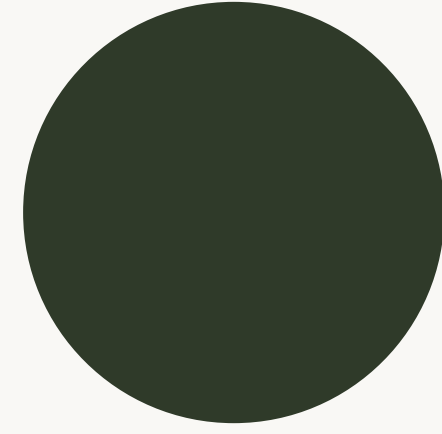

Dark Green  
RAL 6020

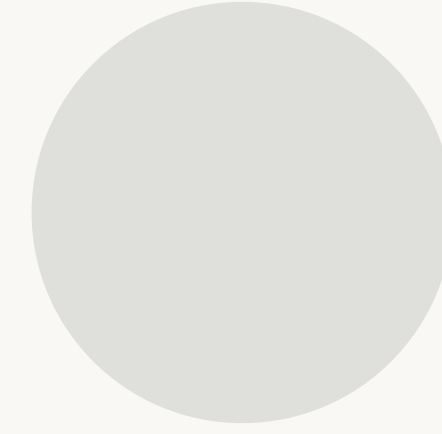

Silk Gray  
RAL 7044

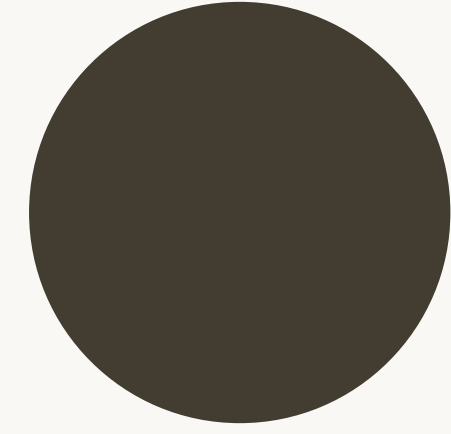

Putty  
RAL 7006

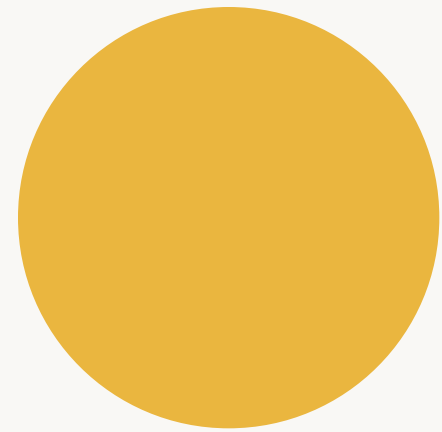

Traffic Yellow  
RAL 1023

# TFL / MFC

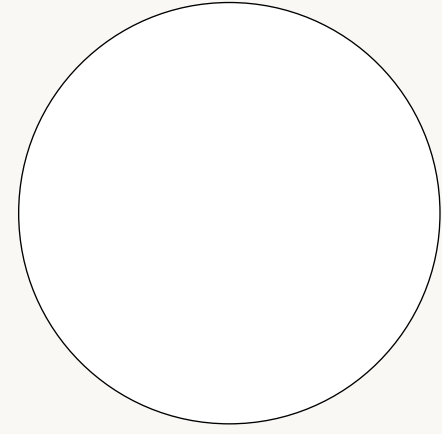

White



Oak



Maple



Walnut

# Fabrics



Camira  
Blazer Napier



Camira  
Blazer Silverdale



Camira  
Blazer Surrey

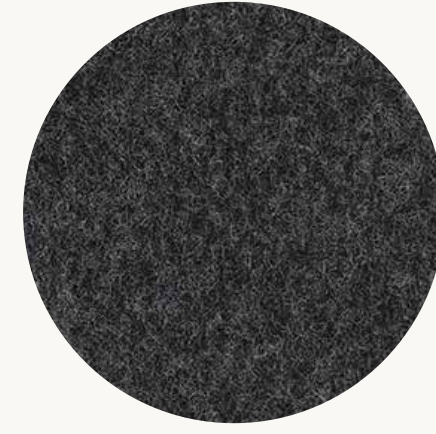

Camira  
Blazer Silcoates



Camira  
Blazer Dartmouth



Camira  
Blazer Edinburgh



Camira  
Blazer Plymouth

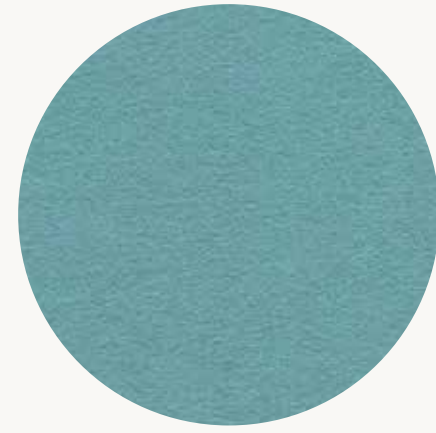

Camira  
Blazer Woodcroft

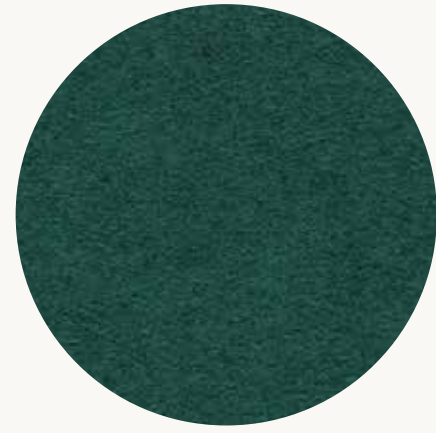

Camira  
Blazer Abertay

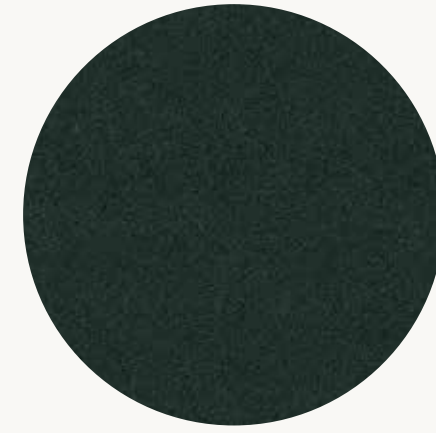

Camira  
Blazer Cardiff

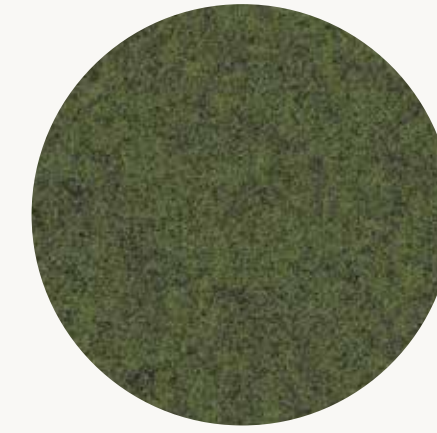

Camira  
Blazer Camphill



Camira  
Blazer Hull



Camira  
Blazer Handcross



Camira  
Blazer Eynesbury



# Flooring:

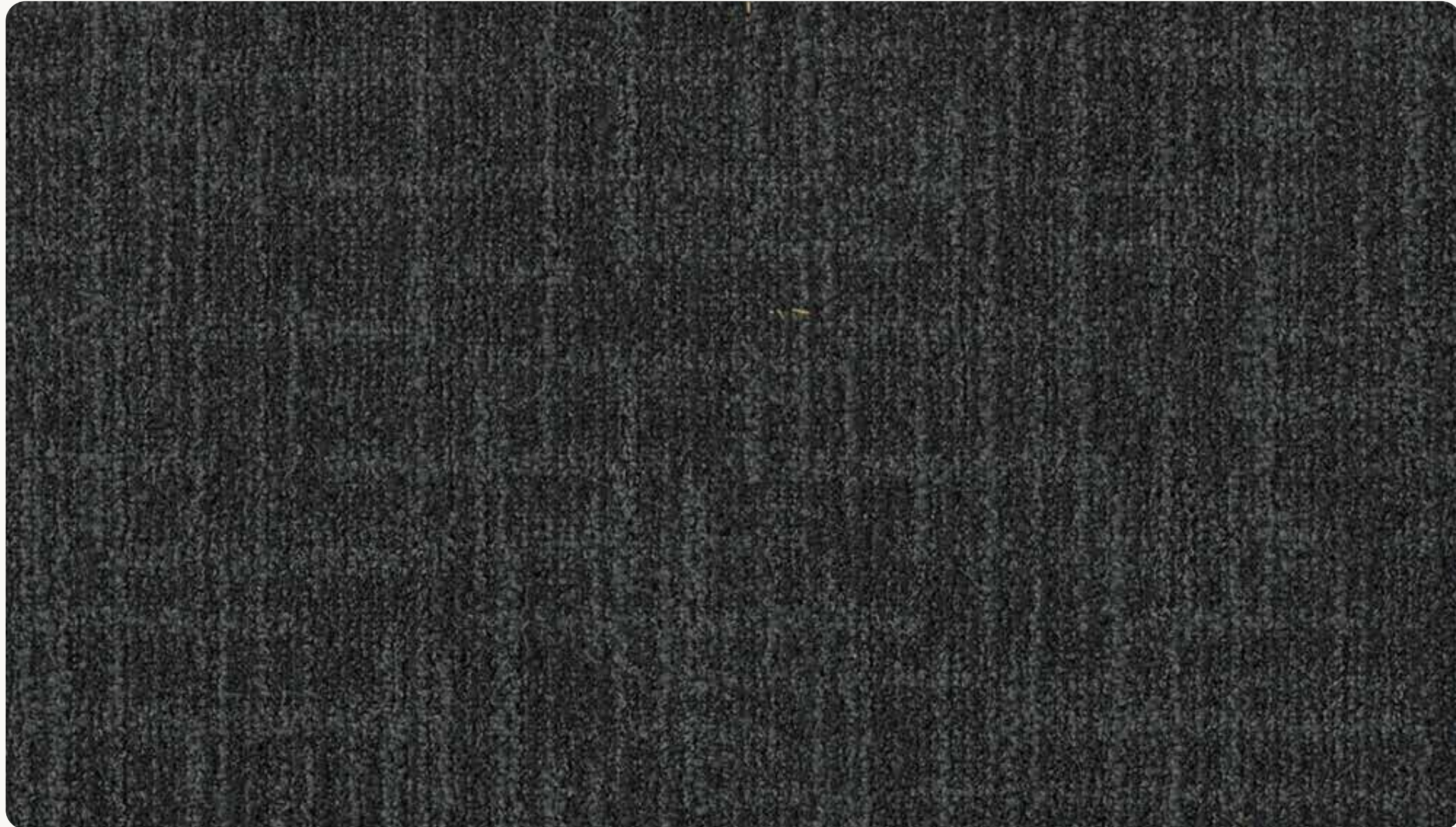

Dark Dansk

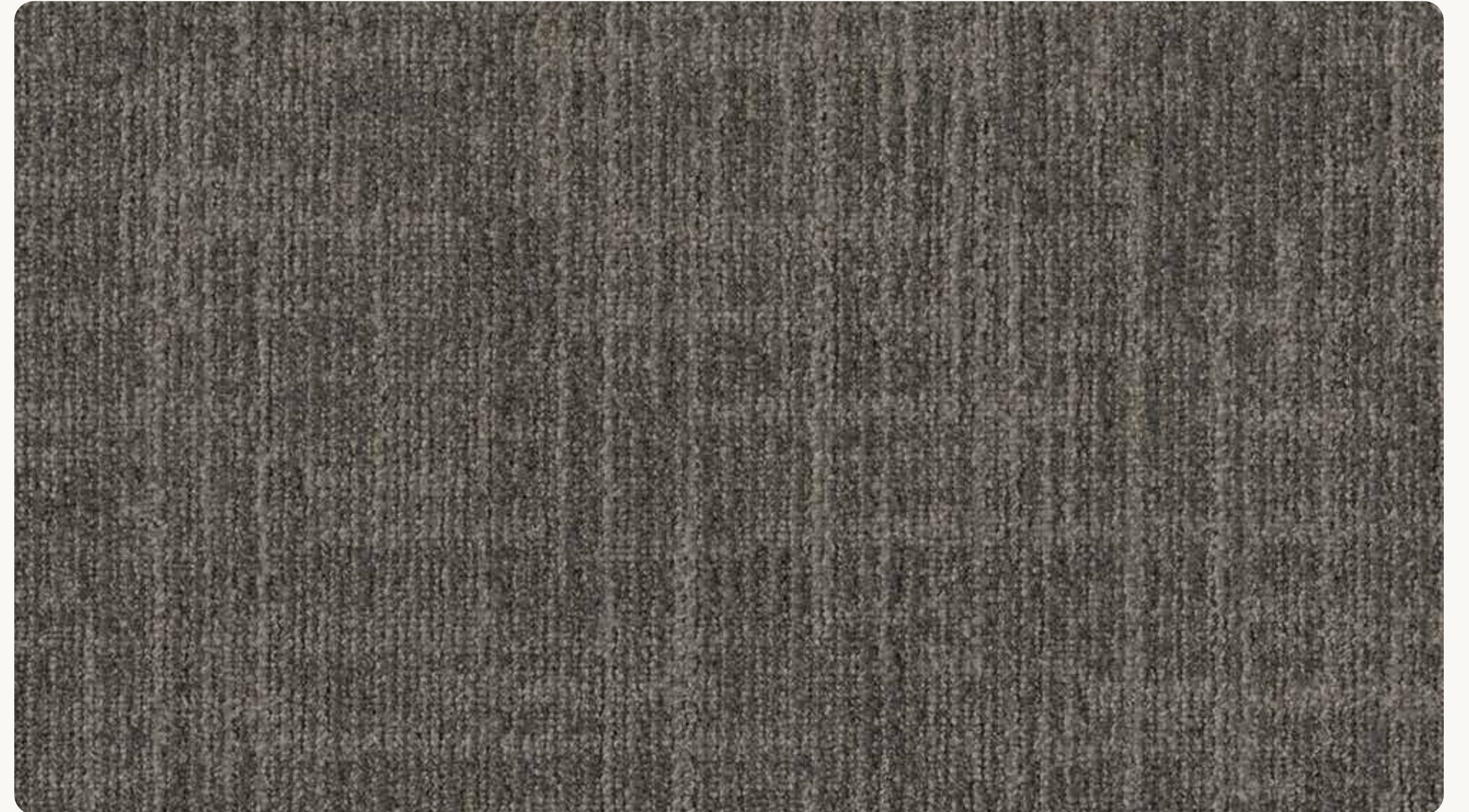

Spiritland

## Where to find us:

### Global Headquarters

Altham Business Park  
Accrington, Lancashire  
BB5 5YE  
United Kingdom

### London

Back Hill  
Farringdon  
London EC1R 5EN  
United Kingdom

### Birmingham

Sovereign Hall  
Frederick Street  
Birmingham B1 3HE  
United Kingdom

### Corporate Headquarters

4111 N. Jerome Road  
Maumee, OH  
43537  
United States

### New York

3 East 28th St, 9th Floor  
New York, NY  
10016  
United States

### Chicago

222 Merchandise Mart Plaza  
Floor 11, Suite 1112  
Chicago, IL  
60654  
United States

### Hong Kong

Suites 2508-2509  
K11 Aterlier  
728 King's Road  
Quarry Bay  
Hong Kong

### Bengaluru

No. 295 & 296, 3rd Floor  
100 Feet Road  
Indiranagar  
Bengaluru 560038  
India

### Dubai

Dubai Marina Plaza  
Floor 22  
Suite 2203  
P.O. Box 116888  
Dubai

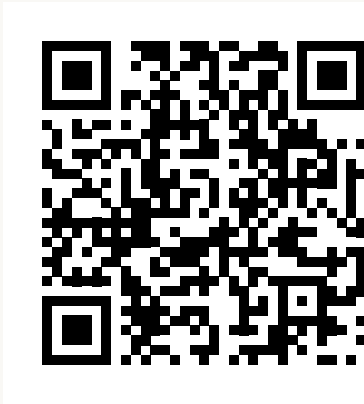

HideAway Product Page



HideAway Configurator