

HideAway

Your place to zone out or tune in.



A place to focus

Isolation isn't about being alone but about having a space to get things done.

We have all embraced online meetings and calls so having a place dedicated to communicate with clients, suppliers and co-workers with the comfort that you have great acoustic privacy and are less likely to be disturbed is essential.

Privacy For Calls

Connect with your colleagues without disturbing the whole office.

Zone Out to Zone In.

Need to focus, the acoustic properties of HideAway enable you to zone in on your work.



Focus



Power, USB and
USB-C enabled



Efficient
Ventilation



Private and
Individual Working



Architectural Features:



Integrated Lighting and Airflow:

As standard all HideAway's are provided with Energy Efficient Occupancy (PIR) activated LED ceiling light and ventilation fan



A Home from Home:

Wall mounted 'floating' worksurface or table finished in TFL / MFC with integrated power.



Functional Exteriors:

The exterior design can be specified to your requirements to create additional collaborative spaces.

A place for hybrid workers

There are times when you just need to get your head down and focus, this could be producing a report or document or for a longer video call with data being shared.

It can be supplied with an integral bench seat or a stand alone chair can be added. The work-surface provides ample room for a laptop, papers, while the connections allow you to hook up to a monitor and camera if you have them installed that create the perfect space for you to participate in a video call.

Privacy For Calls

Connect with your colleagues without disturbing the whole office.

Work Without Worry

Need to focus, the acoustic properties of HideAway enable you to zone in on your work.



Focus



Power, USB and USB-C enabled



Efficient Ventilation



Private and Individual Working



Architectural Features:



A Home from Home:

Wall mounted 'floating' worksurface finished in TFL / MFC with integrated power and HDMI connection to the wall mounted monitor.



Integrated Lighting and Airflow:

As standard all HideAway's are provided with Energy Efficient Occupancy (PIR) activated LED ceiling light and ventilation fan



Moveable:

The exterior design can be specified to your requirements from a selection of colors or drywipe to create additional collaborative spaces. The plinth can be removed to allow the fully built pod to be repositioned.

A place for collaboration

For many now time in the office is about reconnecting with your team, collaborating on a project the HideAway Meeting Pods provide an ideal space for small teams to gather privately, the fantastic acoustic performance allows them to focus on the work they are doing while not disturbing others in the office. The ability to add in an optional table or media screen allows ideas to be shared easily and also allows you to connect with remote team members so everyone is on the same page.

Privacy For Calls

Connect with your colleagues without disturbing the whole office.

Work Without Worry

Need to focus, the acoustic properties of HideAway enable you to zone in on your work.

Meet Freely

Meet together for pre-scheduled or ad hoc meetings in-person or online.



Social



Power, USB and USB-C enabled



Efficient Ventilation



Private and Individual Working



Architectural Features:



Thoughtful Design

The architectural detailing and finishes support the integrity of the design. The provision of lighting, airflow, workspaces and power support its functionality. The impressive acoustic performance gives you privacy.



Well Provisoned

The optional wall mounted meeting table provides a great place to work and its design allows everyone easy access.



Functional Exterior

The exterior panels can be specified in a range of colors and TFL finishes to compliment the interior or as dry wipe panels to provide additional collaborative space.

Zone Out or Tune In.

HideAway is a range of freestanding pods available in 2 - 6 people meeting pods, Telephone Pod and Hybrid Pod designed for privacy and collaboration.

HideAway is an effective solution to empower hybrid workspaces by giving users the acoustic and visual privacy to connect with online and offline colleagues.

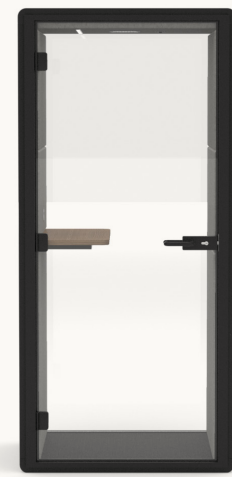

Telephone Pod
One person



Hybrid Work
One person

Can be specified without the bench seat to allow a freestanding task chair to be used



Two Person
with Seating



Four Person
Available with and without seating



Six Person
Available with and without seating

In detail

Telephone Pod
One Person

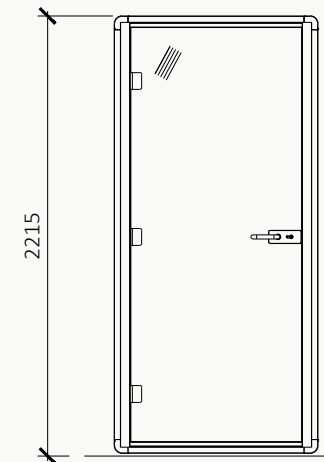
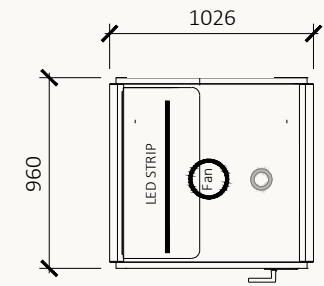

Product Code:
HWYUS01

Structural Framework:

Lightweight composite side panels with outer surface covered in Aluminum finished in standard EPC color options

Glass Panels:

— Glass panels and door, 1/2" laminated clear. Acoustic glass. Front and rear Aluminum Trims finished in Standard EPC color options

Interior:

- Interior fabric clad acoustic tiles, upholstered in Camira Blazer with Acoustic fiber infill as standard.
- Flooring floor tiles, antistatic, available in two finish colors as standard
- Door hardware finished in Black finish

Lighting and Airflow:

- Energy Efficient Occupancy (PIR) activated LED ceiling light and ventilation fan
- Optional external occupancy light strip set in the side panels

Power:

USB A and C charging ports

Workstation:

Wall mounted 'floating' worksurface finished in TFL / MFC. 41.5" AFF (1050mm).

Dimensions:

OH: 2215mm / 87"
OW: 1026mm / 40"
OD: 960mm / 38"

Leveling:

Positioning castors and static position
Leveling feet within the base.

Hybrid Work Pod
One Person

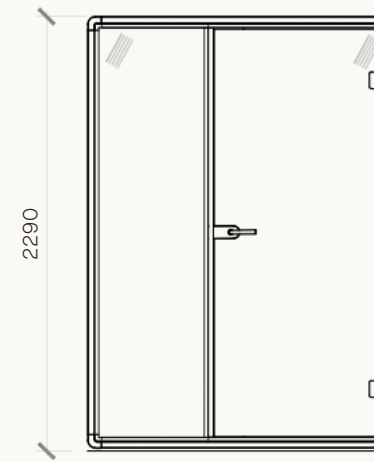
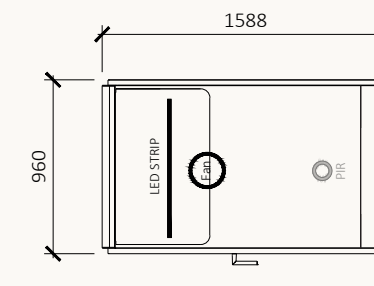

Product Code:
HWYUS01H

Structural Framework:

Lightweight composite side panels with outer surface covered in Aluminum finished in standard EPC color options

Glass Panels:

— Glass panels and door, 1/2" laminated clear. Acoustic glass. Front and rear Aluminum Trims finished in Standard EPC color options

Interior:

- Interior fabric clad acoustic tiles, upholstered in Camira Blazer with Acoustic fiber infill as standard
- Flooring floor tiles, antistatic, available in two finish colors as standard
- Door hardware finished in Black finish
- Optional: Can be specified without bench seat to allow a free standing task chair to be used

Lighting and Airflow:

- Energy Efficient Occupancy (PIR) activated LED ceiling light and ventilation fan
- Optional external occupancy light strip set in the side panels

Power:

1x Power Outlet HDMI and 30W power socket

Workstation:

- Wall mounted 'floating' worksurface finished in TFL / MFC. 29" AFF (740mm).
- Wall mounted VESA plate to mount Monitor with integrated HDMI connection.

Dimensions:

OH: 2290mm / 90"
OW: 1588mm / 62.5"
OD: 960mm / 38"

Leveling:

Leveling feet concealed behind
removable base plinth
Plinth can be removed to enable
the fully built pod to be repositioned
with appropriate equipment

Meeting Pod
Two person

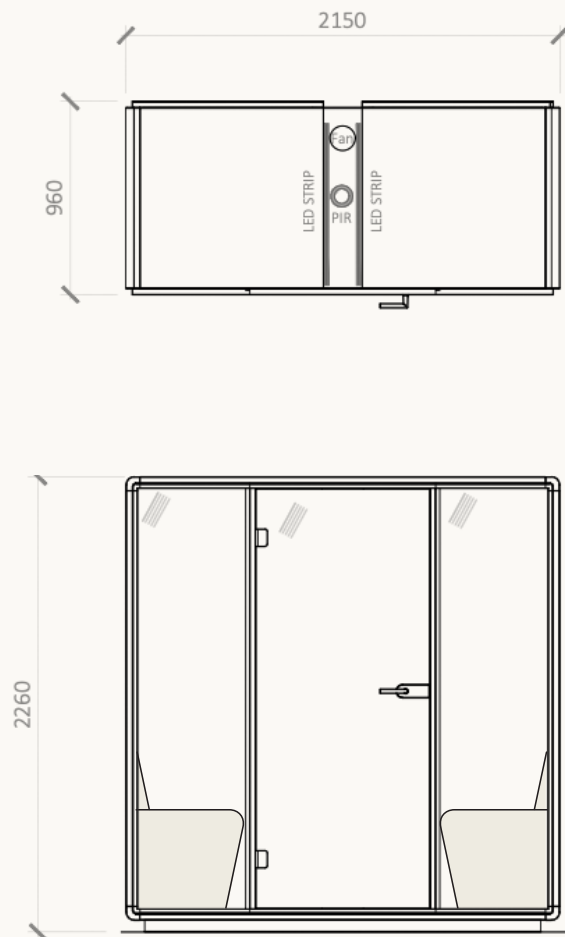

Product Code:
HWYUS02S

Structural Framework:

Lightweight composite side panels with outer surface covered in Aluminum finished in standard EPC color options.

Glass Panels:

- Glass panels and door, 1/2" laminated clear. Acoustic glass. Front and rear Aluminum Trims finished in Standard EPC color options.

Interior:

- Interior fabric clad acoustic tiles, upholstered in Camira Blazer with Acoustic fiber infill as standard.
- Flooring floor tiles, antistatic, available in two finish colors as standard
- Integrated Bench seating fully upholstered in Camira Blazer
- Door hardware finished in Black finish

Lighting and Airflow:

- Energy Efficient Occupancy (PIR) activated LED ceiling light and ventilation fan
- Optional external occupancy light strip set in the side panels

Power:

2x Power Outlet Twin USB-A and USB-C and 30W power socket

Workstation:

Optional internal work shelf.

Dimensions:

OH: 2290mm / 90"
OW: 2150mm / 85"
OD: 960mm / 38"

Leveling:

Leveling feet concealed behind removable base plinth
Plinth can be removed to enable the fully built pod to be repositioned with appropriate equipment

Meeting Pod
Four Person

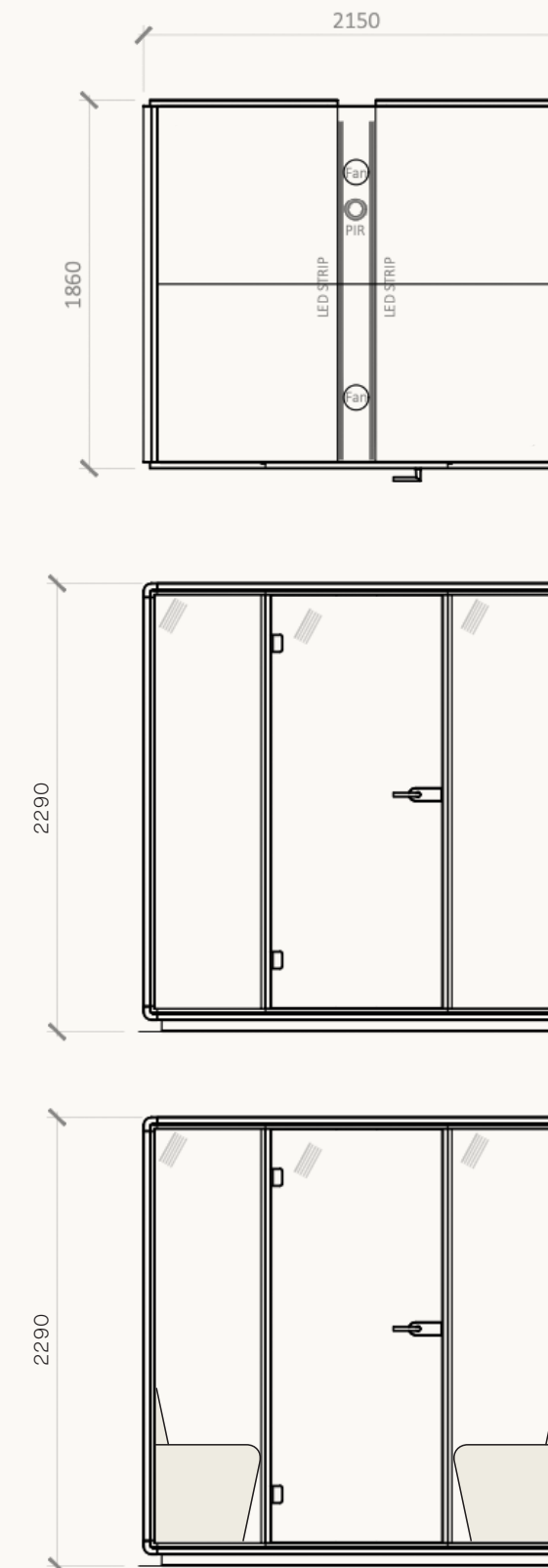

Product Code:
HWYUS03 / HWYUS03S

Structural Framework:

Lightweight composite side panels with outer surface covered in Aluminum finished in standard EPC color options

Glass Panels:

- Glass panels and door, 1/2" laminated clear. Acoustic glass. Front and rear Aluminum Trims finished in Standard EPC color options.

Interior:

- Interior fabric clad acoustic tiles, upholstered in Camira Blazer with Acoustic fiber infill as standard
- Flooring floor tiles, antistatic, available in two finish colors as standard
- Door hardware finished in Black finish
- Optional Integrated Bench seating fully upholstered in Camira Blazer

Lighting and Airflow:

- Energy Efficient switchable LED ceiling light with two preset illumination levels and ventilation fan
- Optional external occupancy light strip set in the side panels

Power:

2x Power Outlet Twin Power Outlet USB-A, USB-C and 30W power socket

Meeting Table:

- Optional Internal meeting table
- Optional internal VESA mount supports up to a 32" screen with HDMI connections

Dimensions:

OH: 2290mm / 90"
OW: 2150mm / 85"
OD: 1860mm / 73"

Leveling:

Leveling feet concealed behind removable base plinth
Plinth can be removed to enable the fully built pod to be repositioned with appropriate equipment

Meeting Pod
Six Person

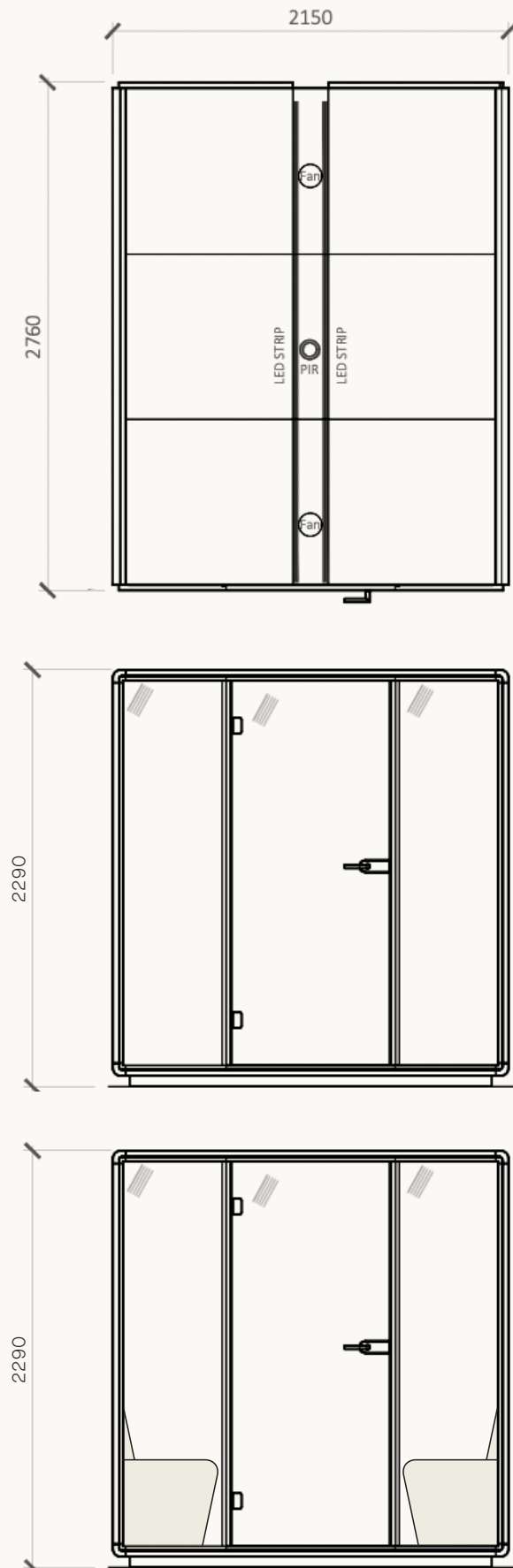

Product Code:
HWYUS04 / HWYUS04S

Structural Framework:

Lightweight composite side panels with outer surface covered in Aluminum finished in standard EPC color options.

Glass Panels:

- Glass panels and door, 1/2" laminated clear. Acoustic glass. Front and rear Aluminum Trims finished in Standard EPC color options

Interior:

- Interior fabric clad acoustic tiles, upholstered in Camira Blazer with Acoustic fibre infill as standard.
- Flooring floor tiles, antistatic, available in two finish colors as standard
- Optional Integrated Bench seating fully upholstered in Camira Blazer
- Door hardware finished in Black finish

Lighting and Airflow:

- Energy Efficient Occupancy (PIR) activated LED ceiling light and ventilation fan
- Optional external occupancy light strip set in the side panels

Power:

Twin Power Outlet USB-A, USB-C and 30W power socket

Meeting Table:

- Optional Internal meeting table
- Optional internal VESA mount supports up to a 32" screen with HDMI connections

Dimensions:

OH: 2290mm / 90"
OW: 2150mm / 85"
OD: 2760mm / 110"

Leveling:

Leveling feet concealed behind removable base plinth
Plinth can be removed to enable the fully built pod to be repositioned with appropriate equipment

A world of color



Paint Finishes

Powder-coated exterior frame - If selecting exterior metal side panels they are finished to match the metal frame as standard.

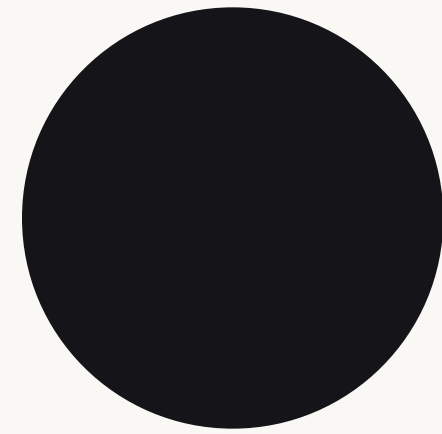

Black

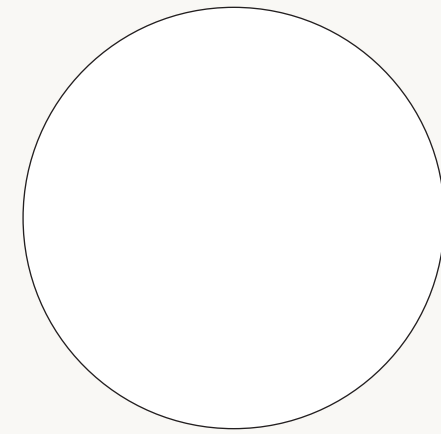

White

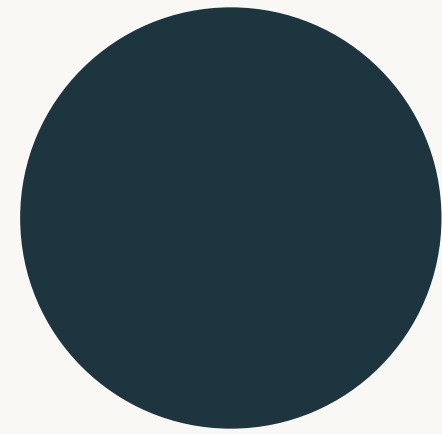

Ocean Blue
RAL 5020

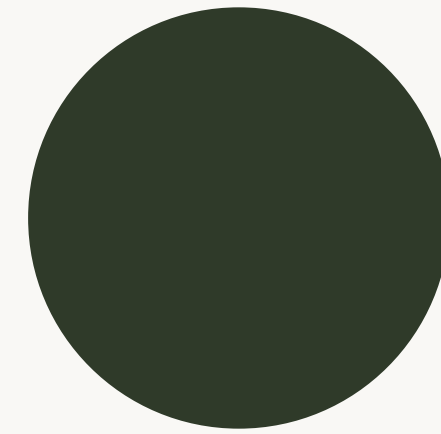

Forest Green
RAL 6020

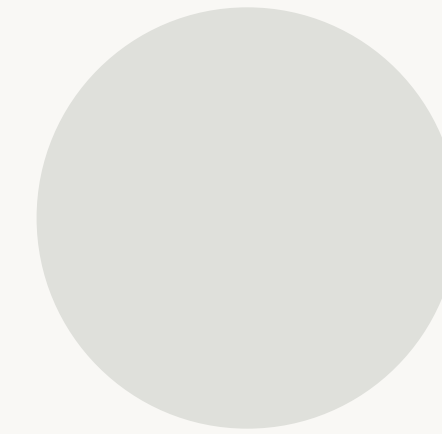

Silk Gray
RAL 7044

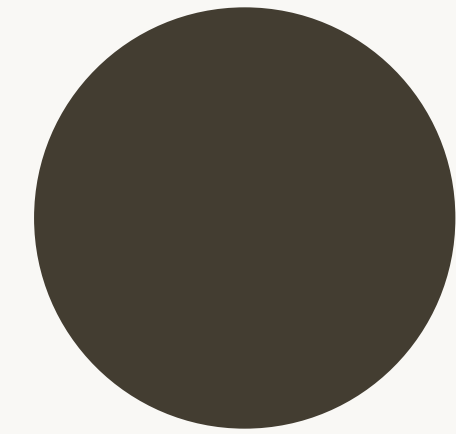

Putty
RAL 7006

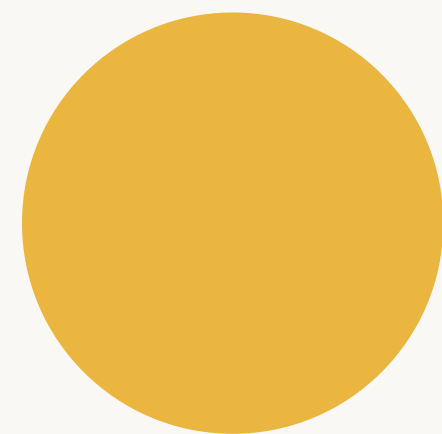

Traffic Yellow
RAL 1023

Laminates & TFL

Exterior panels are available in an optional wood grain finish or whiteboard laminates. Matching TFL finishes available for shelf/table work surfaces not as an exterior panel.

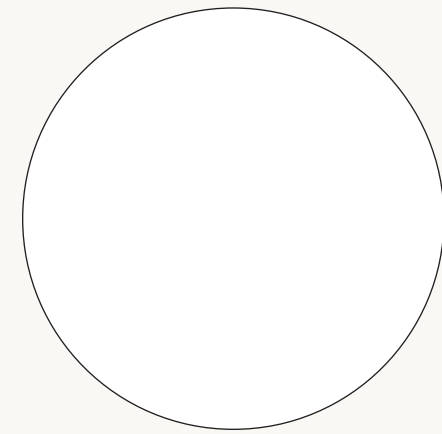

Whiteboard

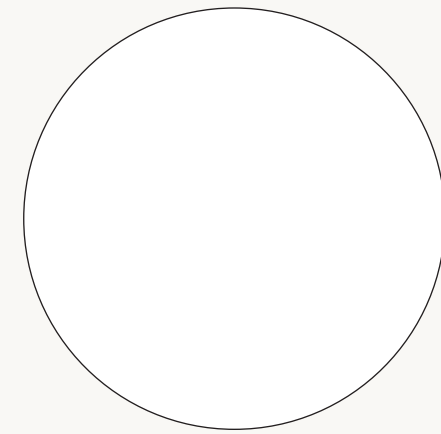

White*



Urban Maple



Natural Casella Oak



Dark Rockford
Hickory

*White TFL/MFC only available as a shelf/table work surface.

Fabrics

All colors from the Camira Blazer Collection are available on HideAway. Only a small selection is shown.

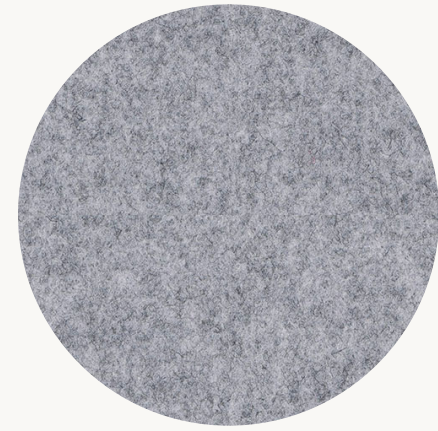

Camira
Blazer Silverdale



Camira
Blazer Surrey



Camira
Blazer Silcoates

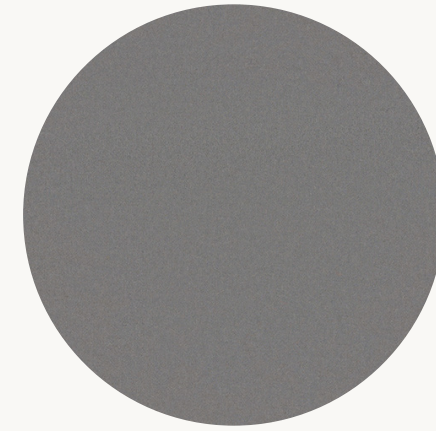

Camira
Blazer Stonebridge



Camira
Blazer Dartmouth

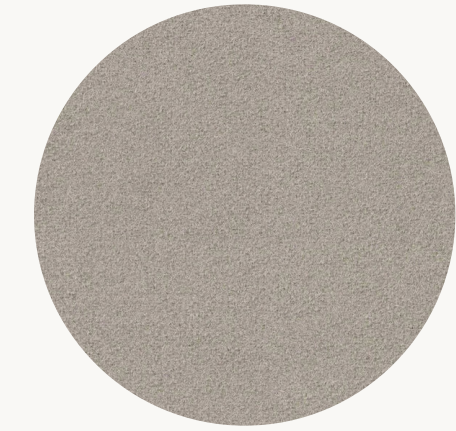

Camira
Blazer Fairfield

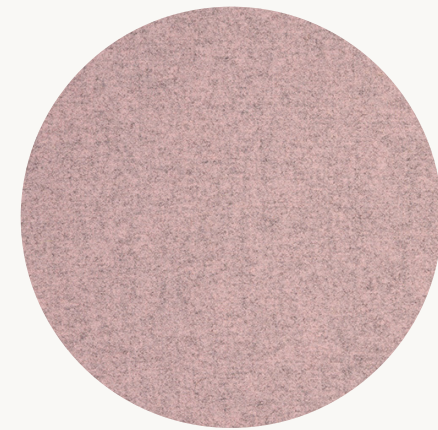

Camira
Blazer Padworth

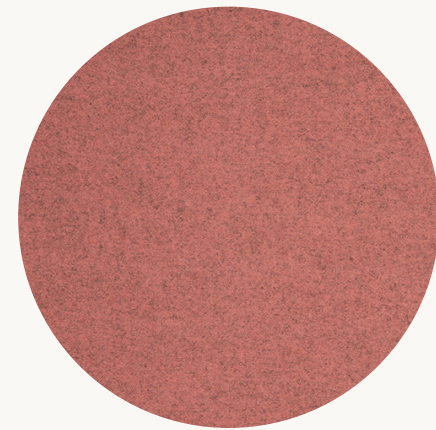

Camira
Blazer Ackworth

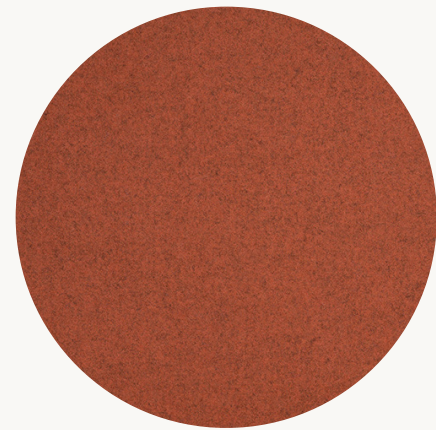

Camira
Blazer Warwick

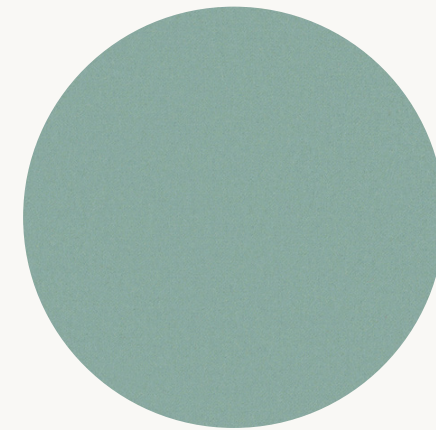

Camira
Blazer Ullswater

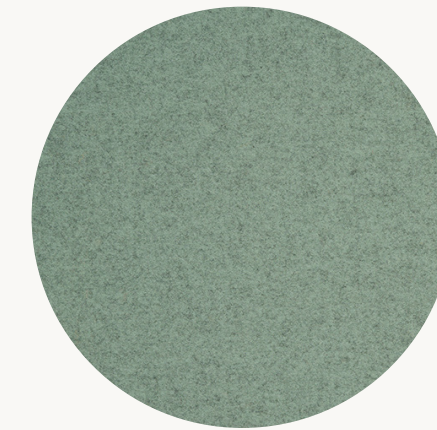

Camira
Blazer Moray

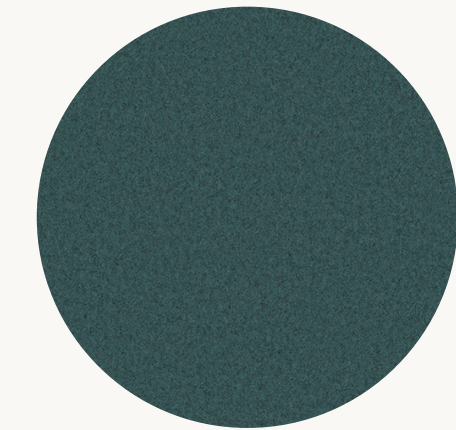

Camira
Blazer Ambleside

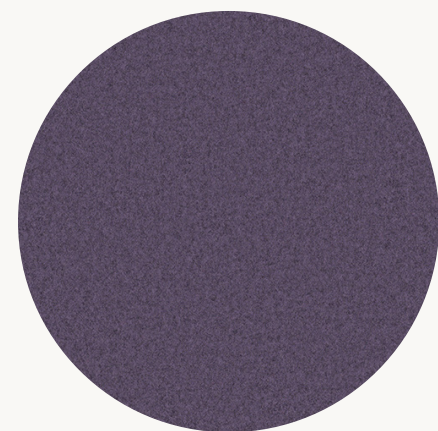

Camira
Blazer Chichester

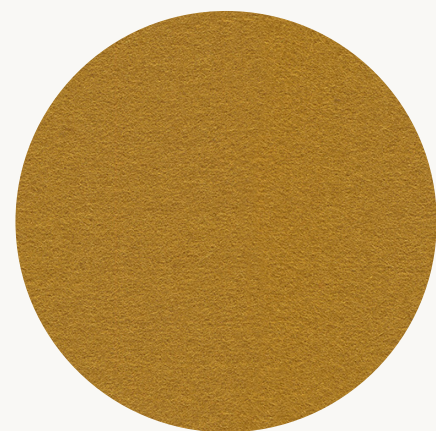

Camira
Blazer Eynesbury

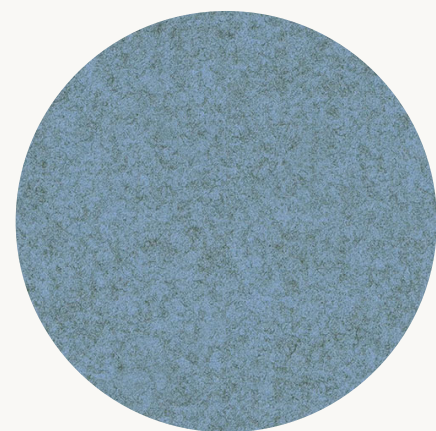

Camira
Blazer Plymouth

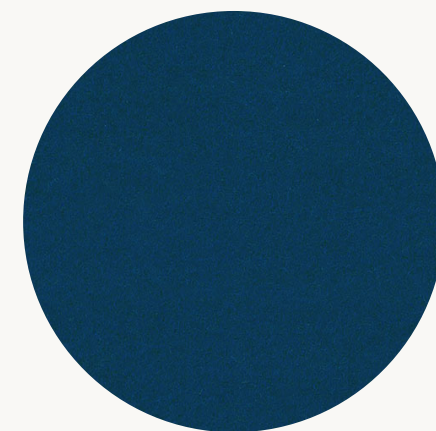

Camira
Blazer Knightsbridge

Flooring:

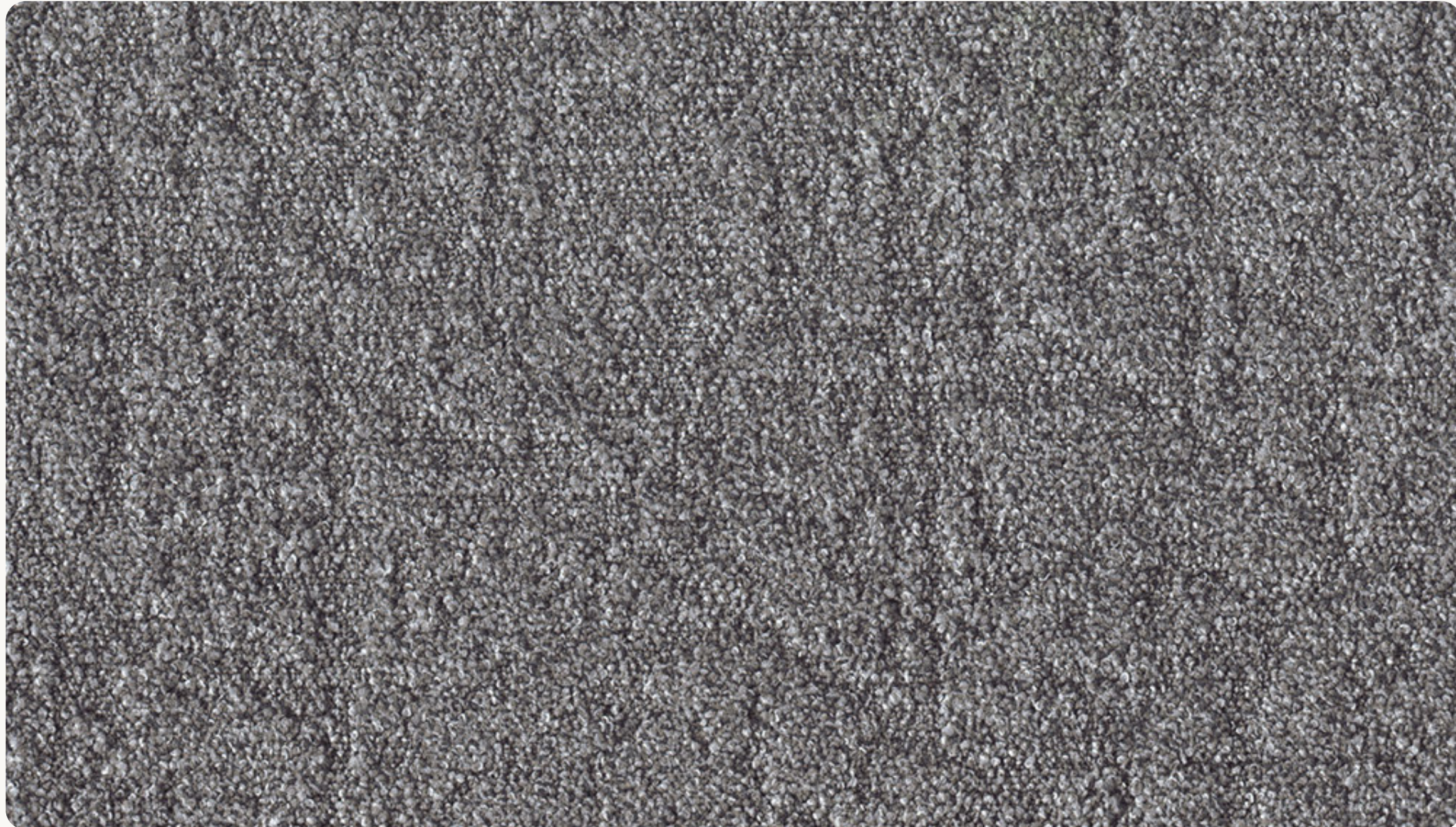

Etch



Marked

Where to find us:

Global Headquarters

Altham Business Park
Accrington, Lancashire
BB5 5YE
United Kingdom

London

Back Hill
Farringdon
London EC1R 5EN
United Kingdom

Birmingham

Sovereign Hall
Frederick Street
Birmingham B1 3HE
United Kingdom

Corporate Headquarters

4111 N. Jerome Road
Maumee, OH
43537
United States

New York

3 East 28th St, 9th Floor
New York, NY
10016
United States

Chicago

222 Merchandise Mart Plaza
Floor 11, Suite 1112
Chicago, IL
60654
United States

Hong Kong

Suites 2508-2509
K11 Aterlier
728 King's Road
Quarry Bay
Hong Kong

Bengaluru

No. 295 & 296, 3rd Floor
100 Feet Road
Indiranagar
Bengaluru 560038
India

Dubai

Dubai Marina Plaza
Floor 22
Suite 2203
P.O. Box 116888
Dubai

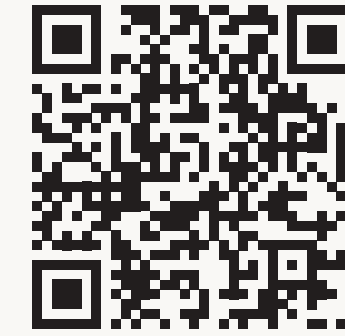

HideAway Product Page



HideAway Configurator